

TYPE 210

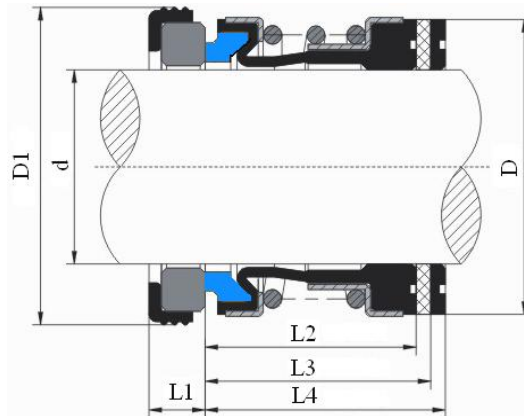

Specification

Temperature : - 40°C ~ 220°C

Pressure : $\leq 18 \text{ kg/cm}^2$

Speed : $\leq 13 \text{ m/sec}$

d	D	D1	L1
3/8	20	22.225	7.9
1/2	24	25.400	7.9
5/8	26	31.750	10.3
3/4	32	34.930	10.3
7/8	36	38.100	10.3
1	39	41.280	11.1
1 1/8	42	44.450	11.1
1 1/4	46	47.630	11.1
1 3/8	49	50.800	11.1
1 1/2	54	53.980	11.1
1 5/8	56	60.330	12.7
1 3/4	61	63.500	12.7
1 7/8	64	66.680	12.7
2	66	69.850	12.7
2 1/8	69	76.200	14.3
2 1/4	77	79.380	14.3
2 3/8	80	82.550	14.3
2 1/2	83	85.730	14.3
2 5/8	88	85.730	15.9
2 3/4	89	88.900	15.9
2 7/8	96	95.250	15.9
3	99	98.425	15.9

d	D	D1	L1	L2	L3	L4
10	20	21	5	15	27.5	35
12	22	23	6	15	26.5	34
14	24	25	6	15	29.0	34
15	25	26	6	15	29.0	34
16	26	27	6	15	29.0	34
18	32	33	6	20	31.5	39
20	34	35	6	20	31.5	39
22	36	37	6	20	31.5	39
24	38	39	6	20	34.0	44
25	39	40	6	20	34.0	44
28	42	43	6	26	36.5	44
30	44	45	7	26	35.5	43
32	46	48	7	26	35.5	48
33	47	48	7	26	35.5	48
35	49	50	8	26	34.5	47
38	54	56	8	30	37.0	47
40	56	58	8	30	37.0	47
43	59	61	8	30	37.0	52
45	61	63	8	30	37.0	52
48	64	66	10	30	35.0	50
50	66	70	10	30	37.5	50
53	69	73	10	30	37.5	60
55	71	75	10	30	37.5	60
58	78	78	10	30	42.5	60
60	80	80	12	30	40.5	58
63	83	83	12	30	40.5	58